



SEALING PROFILES

ASSOTECH ARTICOLI TECNICI IN GOMMA, PLASTICA E SILICONE





PRODUZIONE (PRODUCTION)

Estrusioni mono miscela, CO-estrusi, con inserto tessile/ lamierino.
Applicazione butile, hot melt, vernice, flock e biadesivi.
Lavorazioni di giunta tramite vulcanizzazione o incollaggio.
Fustellatura, fresatura e taglio a misura.

*(Mono-compound extrusion, co-extruded profiles, with textile/metal insert.
Butyl, hot melt, varnish, flock and double-tape adhesives application.
Joint activities by vulcanization or gluing.
Die-Cutting, milling and cutting to length.)*

CONSULENZA E PROGETTAZIONE (CONSULTANCY AND DESIGN)

Articoli tecnici in GOMMA, PLASTICA e SILICONE.
Impianti tecnologicamente all'avanguardia.
Qualità del processo e del prodotto.
Soluzione su misura per ogni esigenza.

*(Technical articles in RUBBER, PLASTIC and SILICON
Technologically advanced Machineries
Process and product quality
Tailor-made solutions for every exigency)*

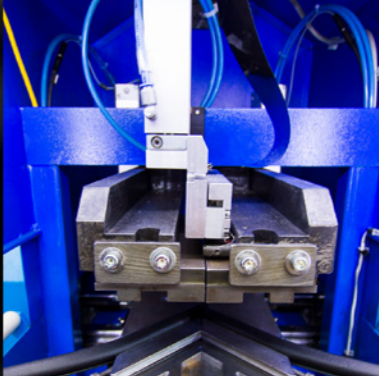
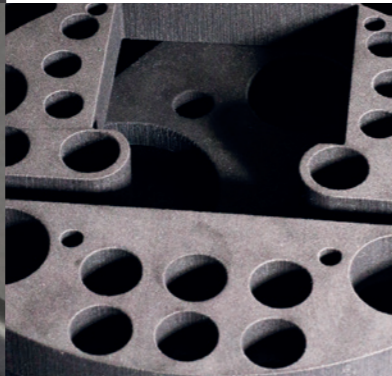
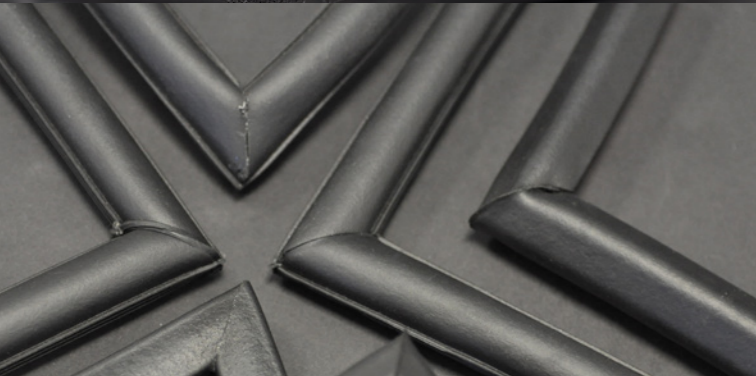

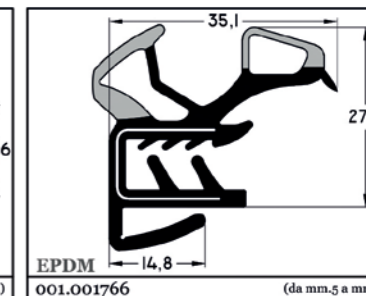
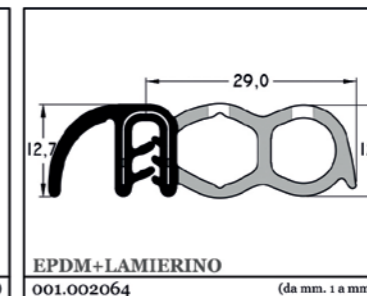
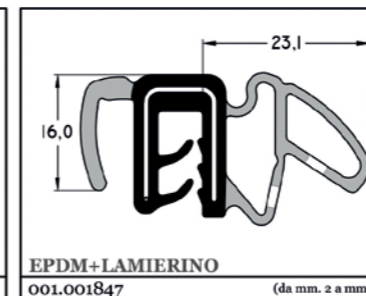
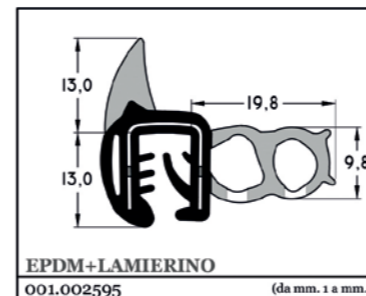
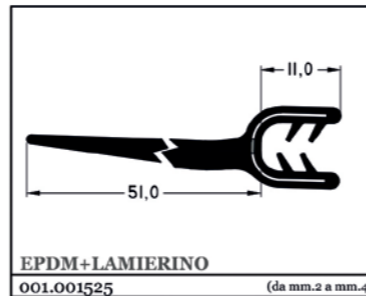
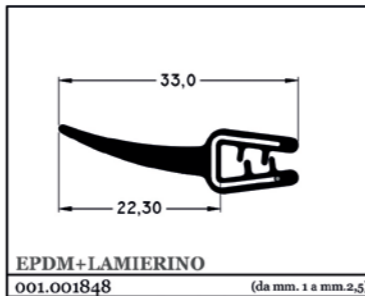
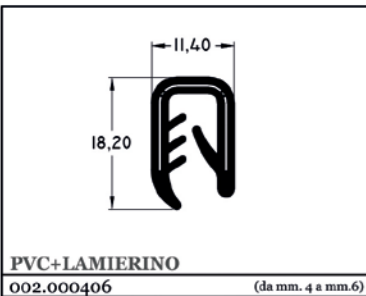
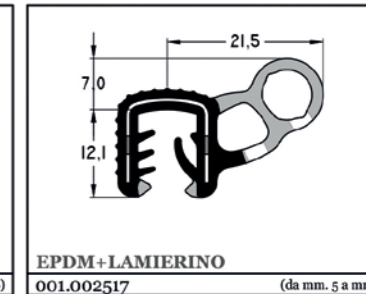
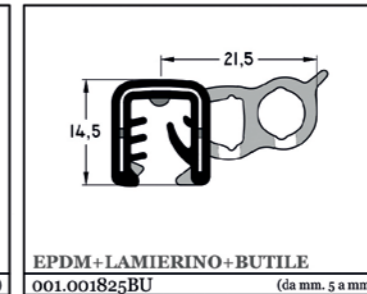
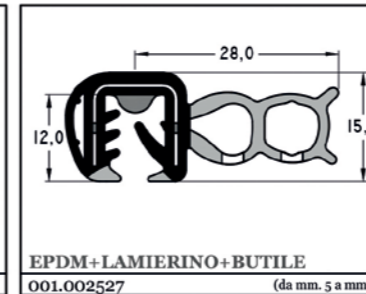
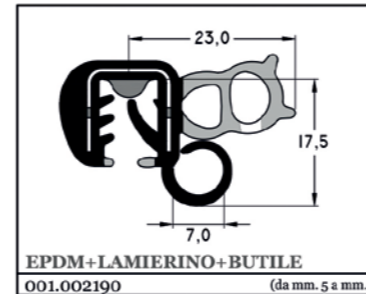
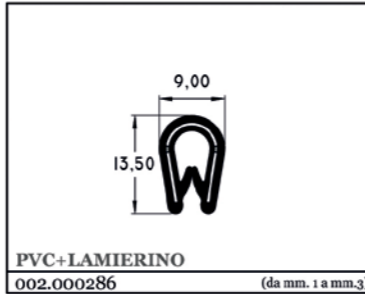
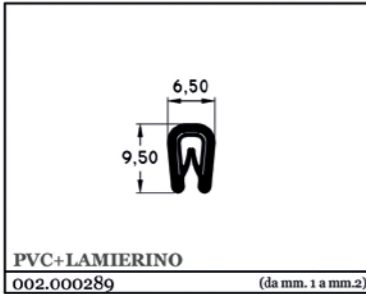
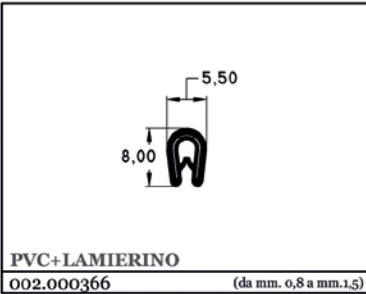
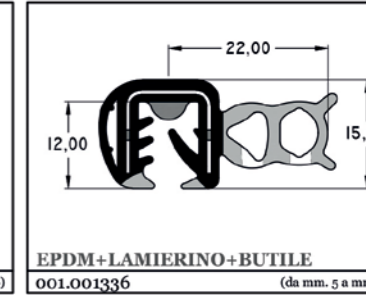
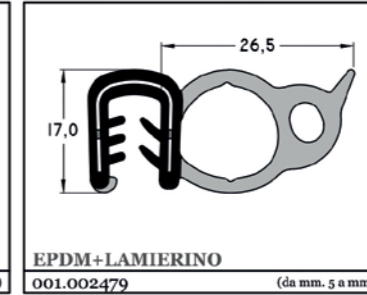
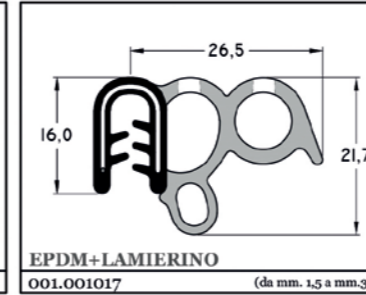
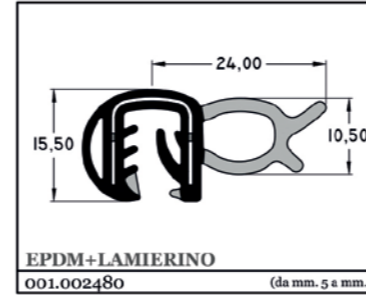
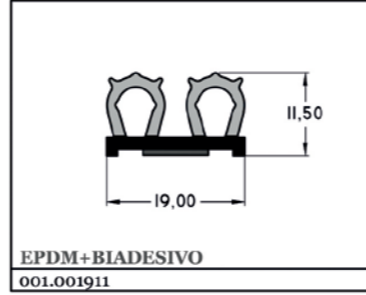
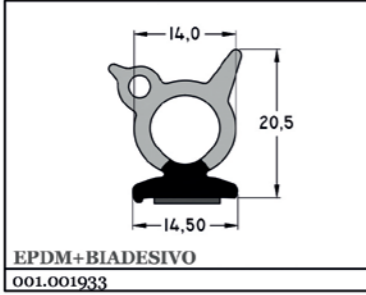
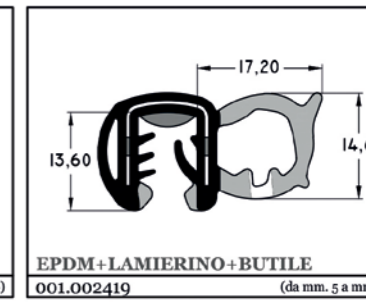
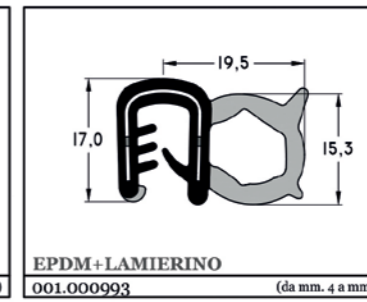
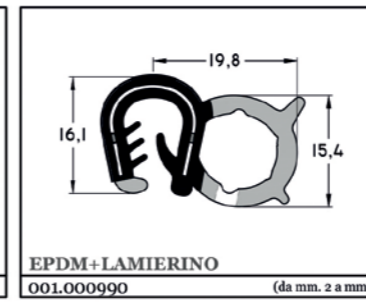
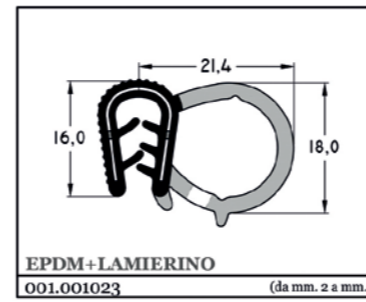
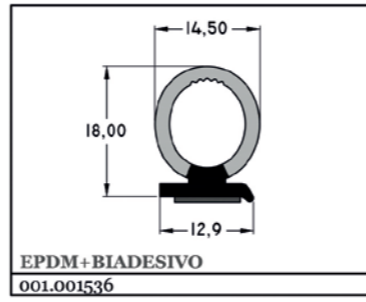
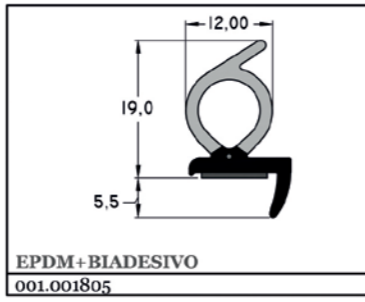
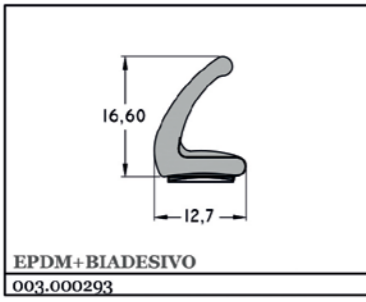
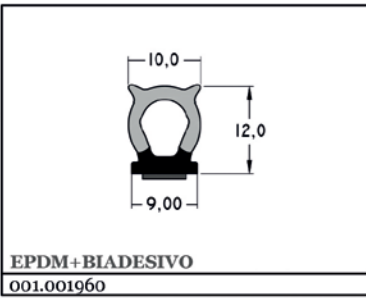
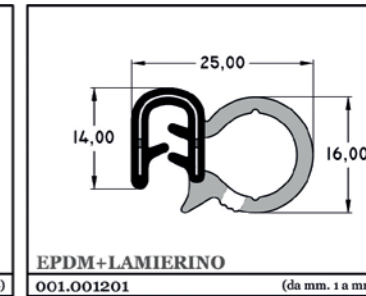
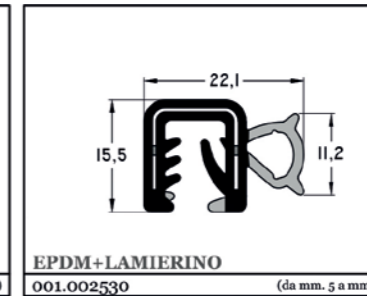
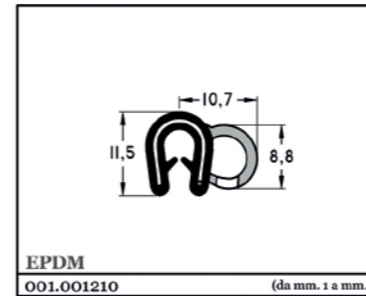
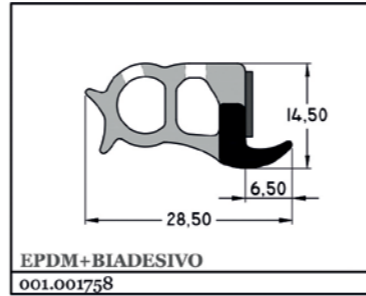
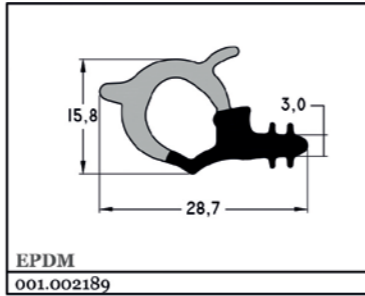
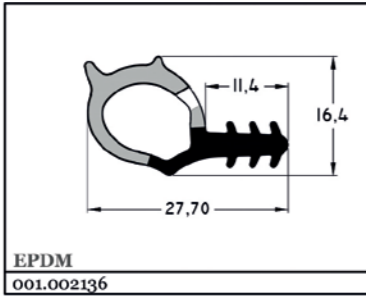
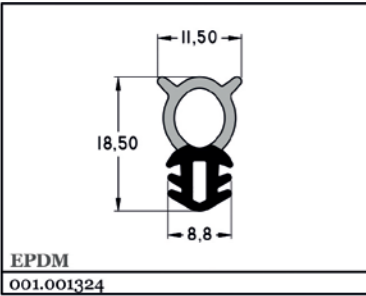

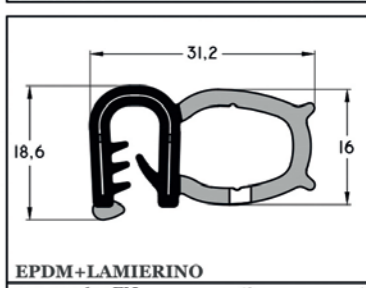
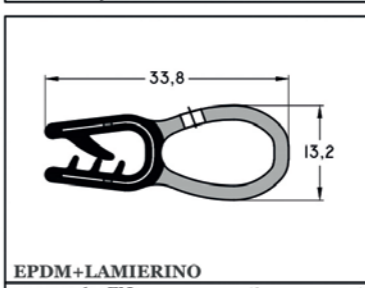
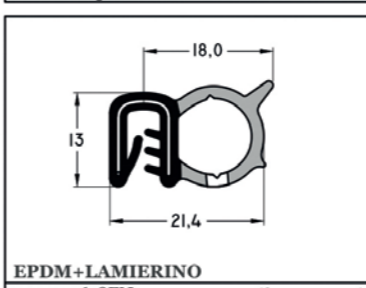
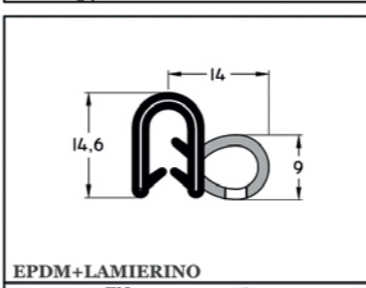
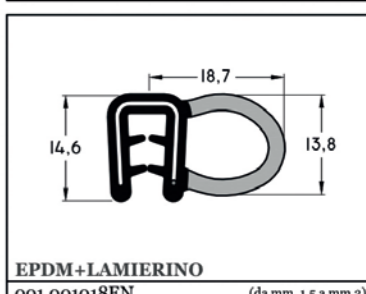
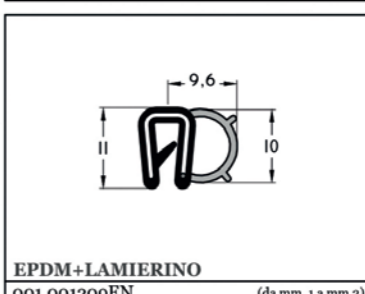
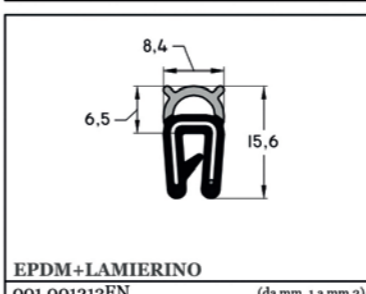
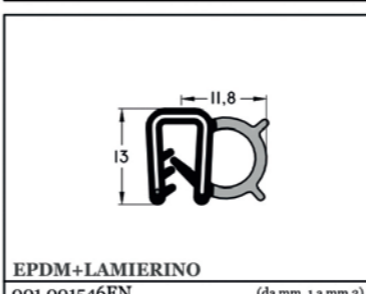
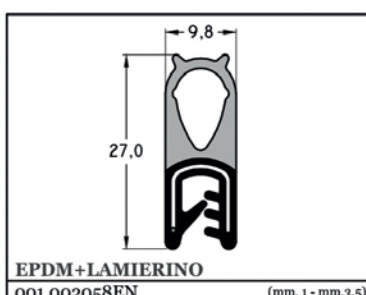
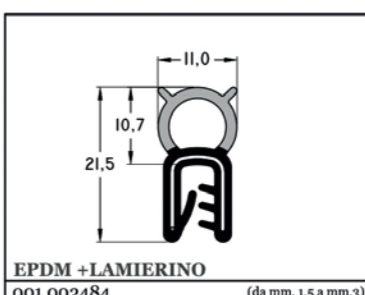
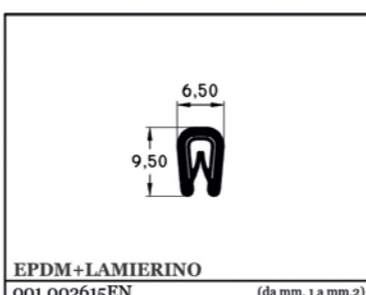
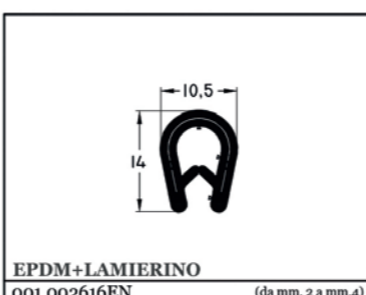
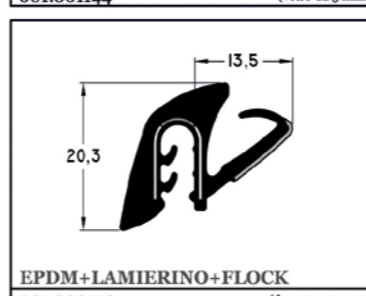
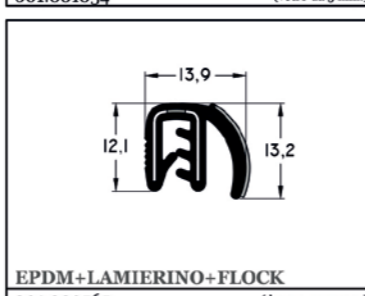
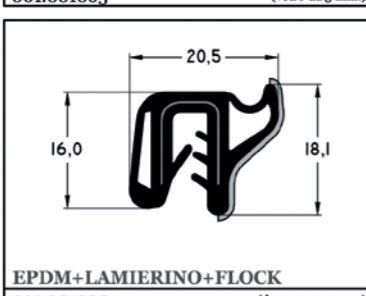
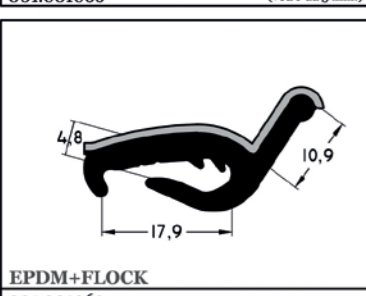
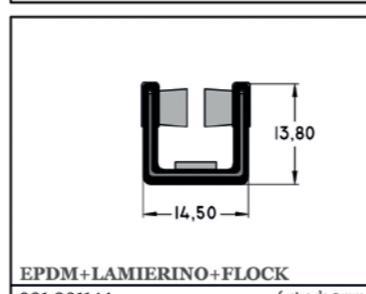
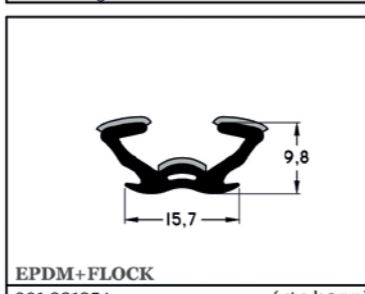
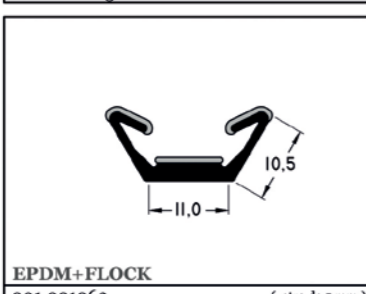
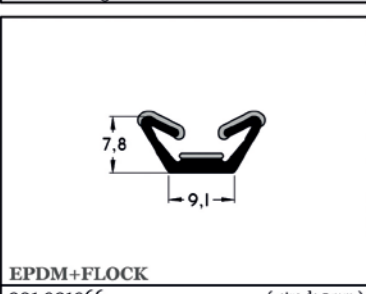
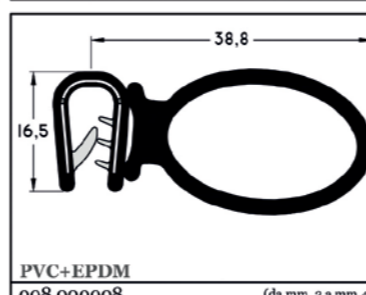
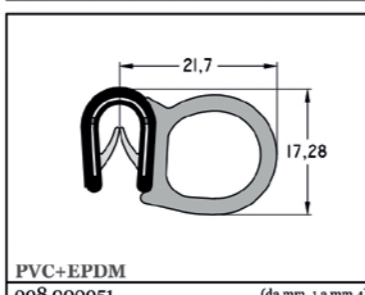
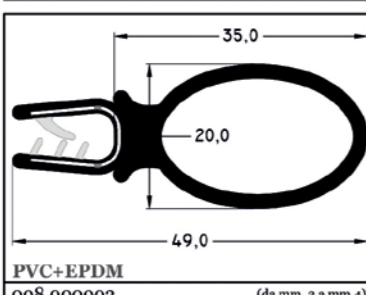
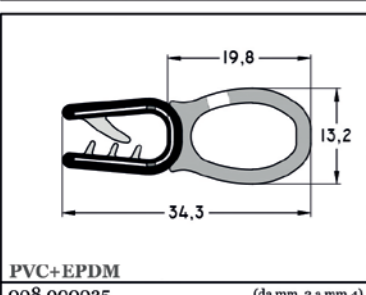
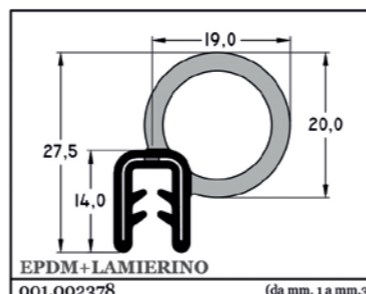
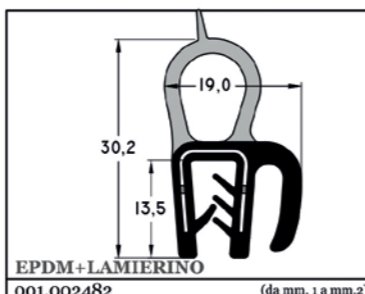
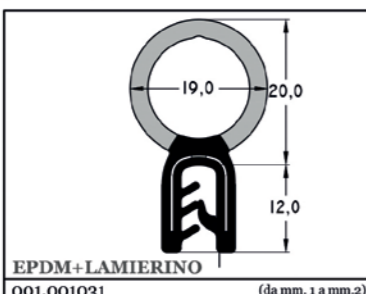
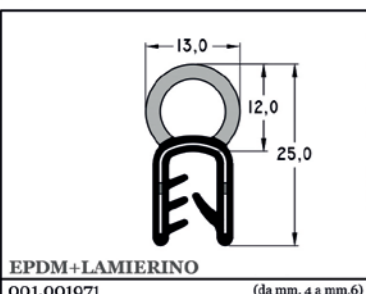
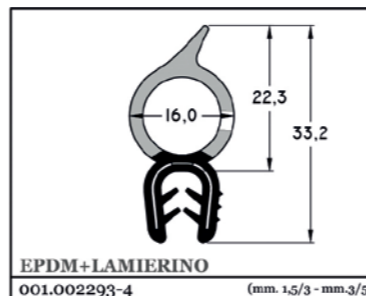
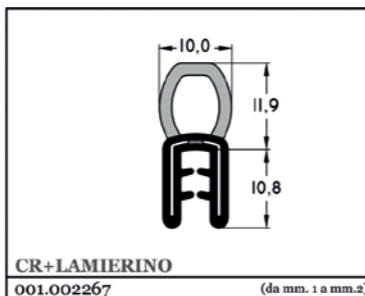
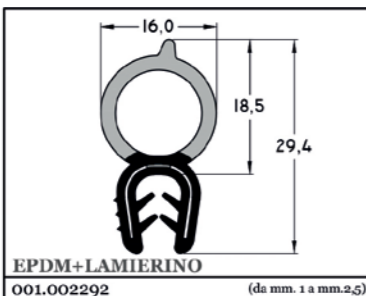
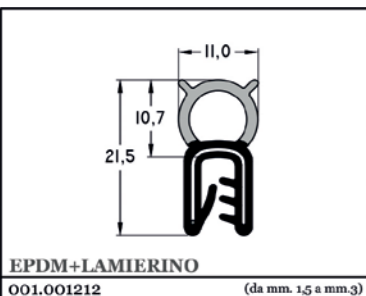

SETTORI DI IMPIEGO E APPLICAZIONE

USE AND APPLICATION SECTORS

ASSOTECH è in grado di ricoprire tutte le esigenze di tenuta di aria, acqua, polveri o calore nell'ambito della meccanica industriale. La nostra professionalità ci ha portato ad essere fornitore primario di importanti Brand Mondiali nei principali settori industriali quali:

ASSOTECH is able to cover all the needs of air, water, dust or heat tightness in industrial mechanics. Our professionalism has led us to be primary supplier of important world brand in key industrial sectors such as: AGRICULTURE, RAILWAY, AUTOMOTIVE, CARAVAN, INDUSTRIAL CLEANING, ENERGY, ELECTRIC CARS, INDUSTRIAL FORKLIFTS.

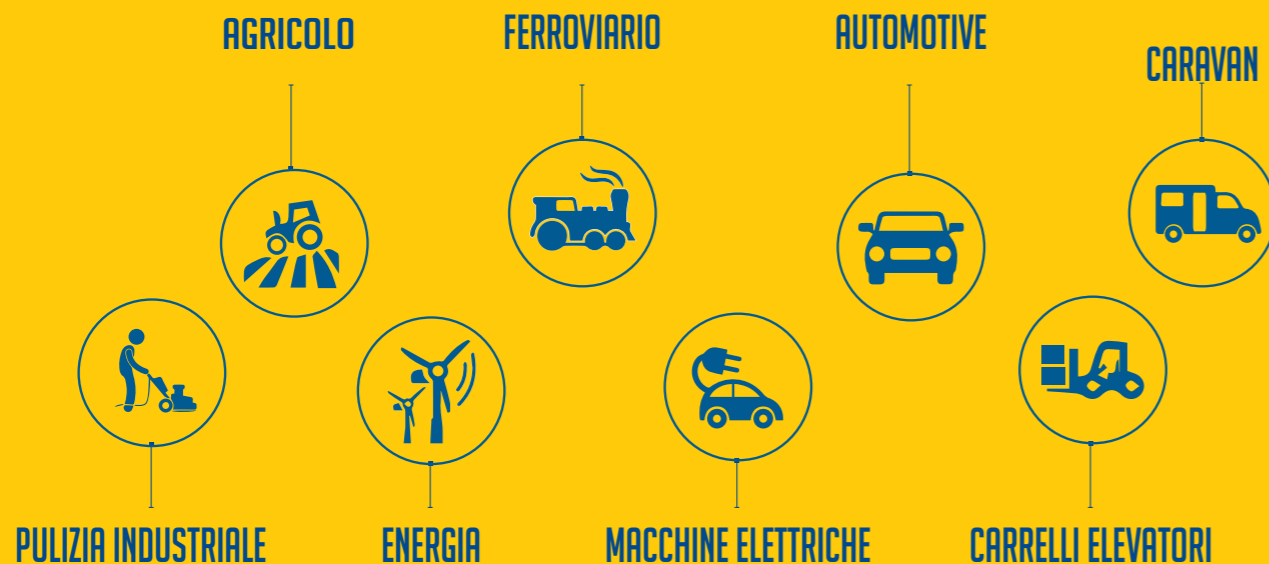

MESCOLE COMPATTE

EPDM – CR – NBR – SILICONE
(Durezza SHORE A 50-60-70-80-90)

MESCOLE TERMOPLASTICHE

PVC o TPE
(Durezza SHORE A 50-60-70-80-90)

MESCOLE ESPANSE

EPDM – CR – NBR – SILICONE
(Densità gr/cm³ 0,4 – 0,5 – 0,6 – 0,8)

AUTOMOTIVE

FCA, IVECO, BMW, MAN, VW, DBL
Mercedes Benz

MESCOLE, CONFORMITÀ E CERTIFICAZIONI.

ALIMENTARE

FDA1772600

SICUREZZA

FMVSS302 EG 95/28, ECE-R118 (USA)
CMVSS302 (CDN)

FERROVIARIO

EN 45545-2, R22/ R23 HL3 – HL2 (UE)
DIN 5510-2 (D)
NFF 16-101 (F)
CEI 11170-2 (I)
BS 6853 (GB)

INFIAMMABILITÀ

UL94 (USA)
UL 50 (USA)

40 ANNI DI ESPERIENZA FANNO LA DIFFERENZA. 40 YEARS OF EXPERIENCE MAKE THE DIFFERENCE

Grazie alla lungimiranza del suo fondatore, alla continuità garantita dai figli oggi ai vertici dell'azienda, ad una strategia di coinvolgimento globale del suo team lavorativo e a collaborazioni sempre più affiatate con i propri clienti e fornitori, la prospettiva aziendale di Assotech è sempre in crescita. Ma non ci accontentiamo mai: la Dirigenza Assotech è costantemente impegnata nel mettere a punto strategie idonee per migliorare la struttura ed il proprio posizionamento sul mercato nazionale ed internazionale.

Thanks to the foresight of its founder, the continuity guaranteed by the sons who are today at the top of the company, to a strategy for the global involvement of its work Team and increasingly close-knit partnerships with its customers and suppliers, Assotech's corporate perspective is always growing. But we are never satisfied: Assotech Leadership is constantly engaged in developing suitable strategies to improve its structure and its position in the domestic and international market.

UN SUCCESSO COSTRUITO SUL FUTURO

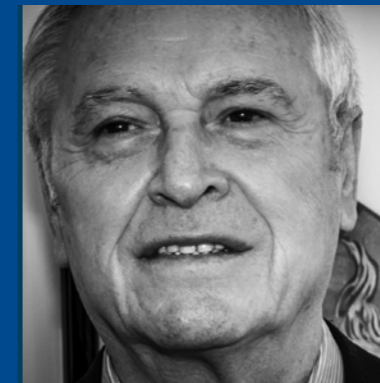

FUSTELLATURA DA LASTRA A DISEGNO (DIE-CUTTING ON RUBBER SHEET FROM A DRAWING)

Lavorazione di fustellatura di materiali compatti o espansi, tramite taglio plotter o fustella.

Die-cutting process of compact and foamed rubber, through plotter cut or die-cut tool

ESTRUSIONE MONO, BI E TRICOMPONENTE (ONE-, BI-, THREE-COMPONENT EXTRUSION)

Mescole EPDM, NBR, Silicone, TPE, TPV e Termoplastici
Mescole certificate UL94, EN45545, FDA.

EPDM, NBR, Silicone, TPE, TPV and Thermoplastic compounds.
UL94, EN45545 and FDA certified compounds.

PROTOTIPAZIONE RAPIDA 3D (3D RAPID PROTOTYPING)

Prototipazione rapida in diversi materiali per poter testare la geometria sviluppata prima della costruzione della matrice.

Rapid prototyping for different material to test the projected shape before developing the related tool.

PRESSA DI VULCANIZZAZIONE (GIUNTE) (VULCANIZATION PRESS - JOINTS)

Sistemi di giunta a freddo tramite specifici collanti oppure a caldo tramite vulcanizzazione a foglietta, ad iniezione e a compressione.

Cold joints process by the use of specific glues or hot joints process through the use of rubber sheets, through injection and compression.



www.assotech.com

ASSOTECH s.r.l.
Via Nazionale, 55/11
40065 Pianoro (BO) - Italy
Tel. (+39) 051 743806
Fax (+39) 051 743607

assotech@assotech.com



IL NOSTRO
OBIETTIVO È
LA VOSTRA
SODDISFAZIONE



*OUR GOAL IS
YOUR SATISFACTION*

